

# MAGNUM

## Cartridge Bearing Seals



Isomag technology in easy to  
install one piece designs



# MAGNUM

## Cartridge Bearing Seals

### EASY TO INSTALL

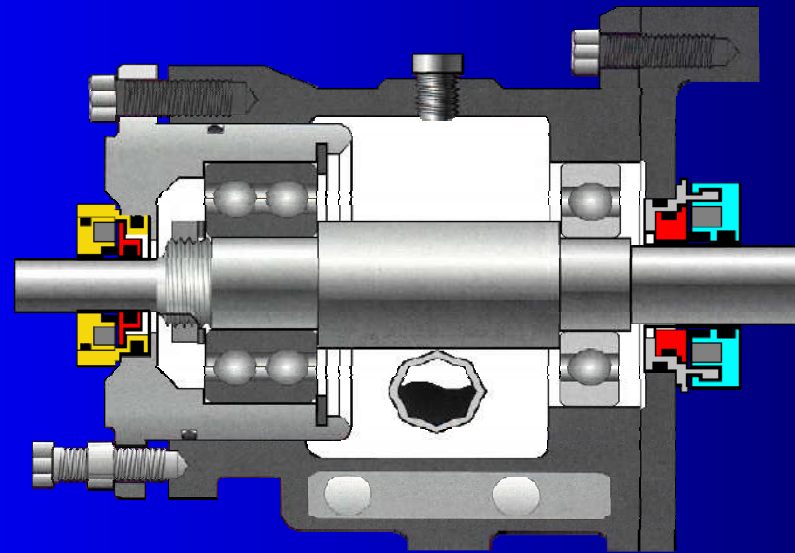

# MAGNUM

## Cartridge Bearing Seals

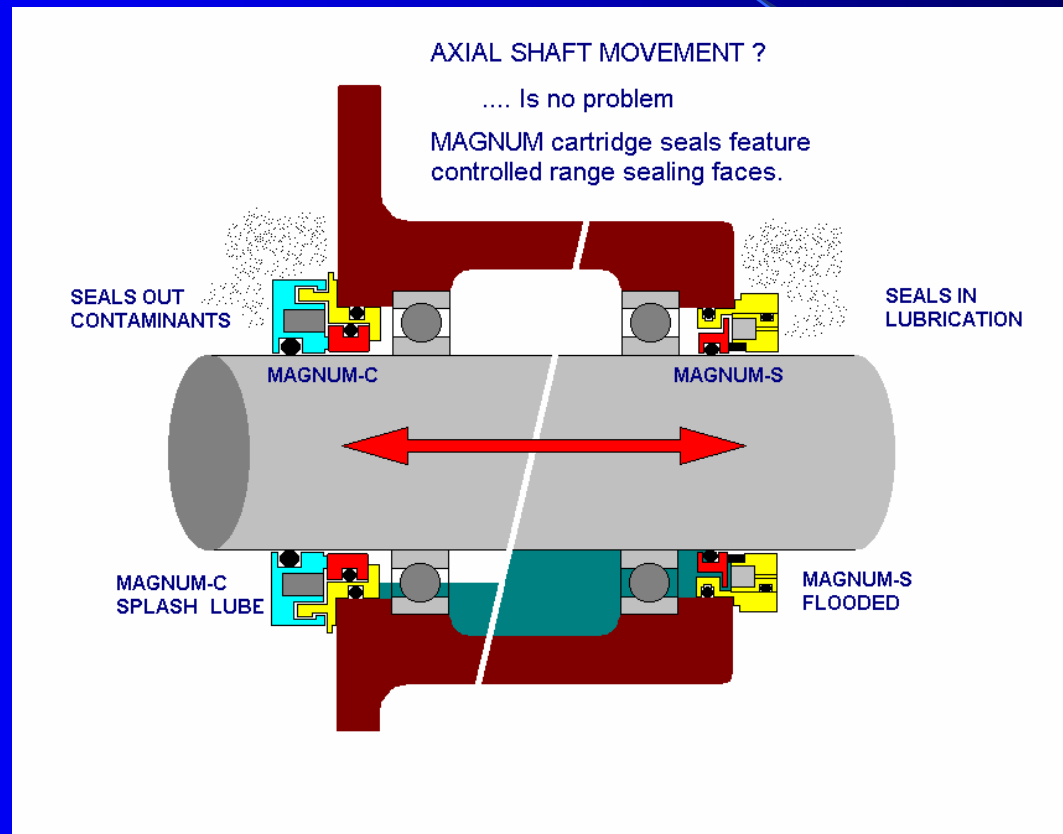

Controlled range magnetic face loading



# MAGNUM-C CARTRIDGE BEARING SEAL



**ISOMAG**

# MAGNUM -C

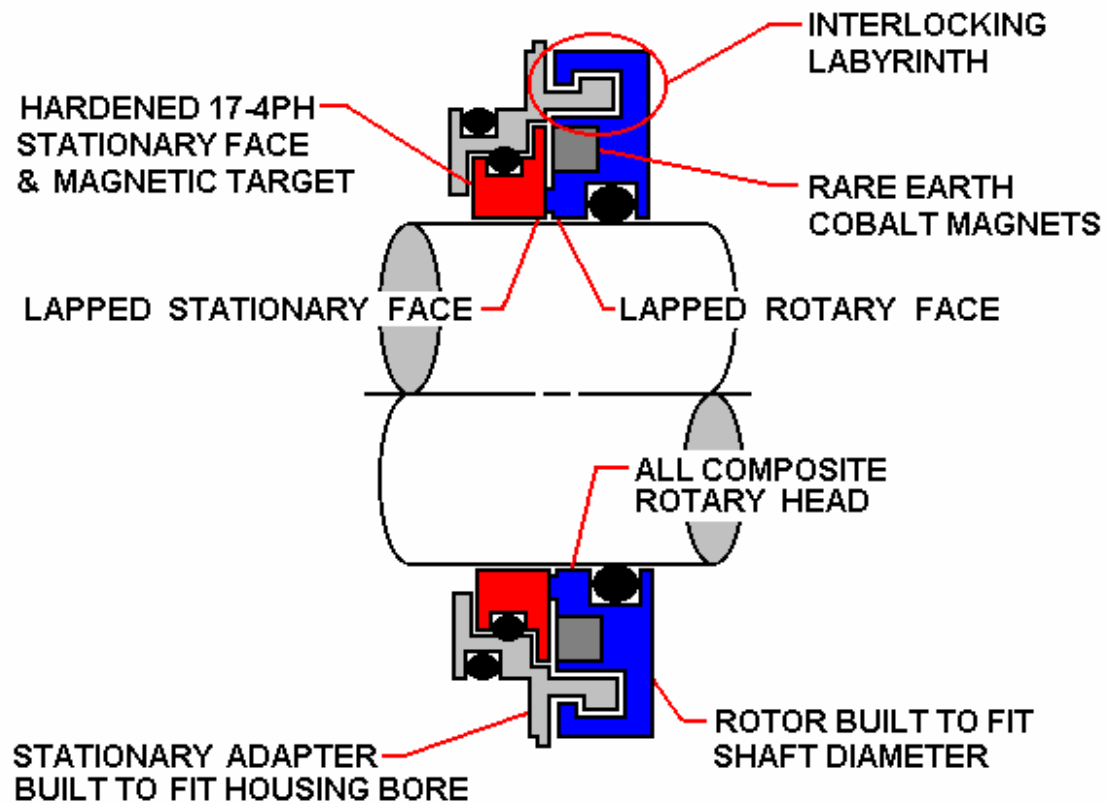

# MAGNUM-C

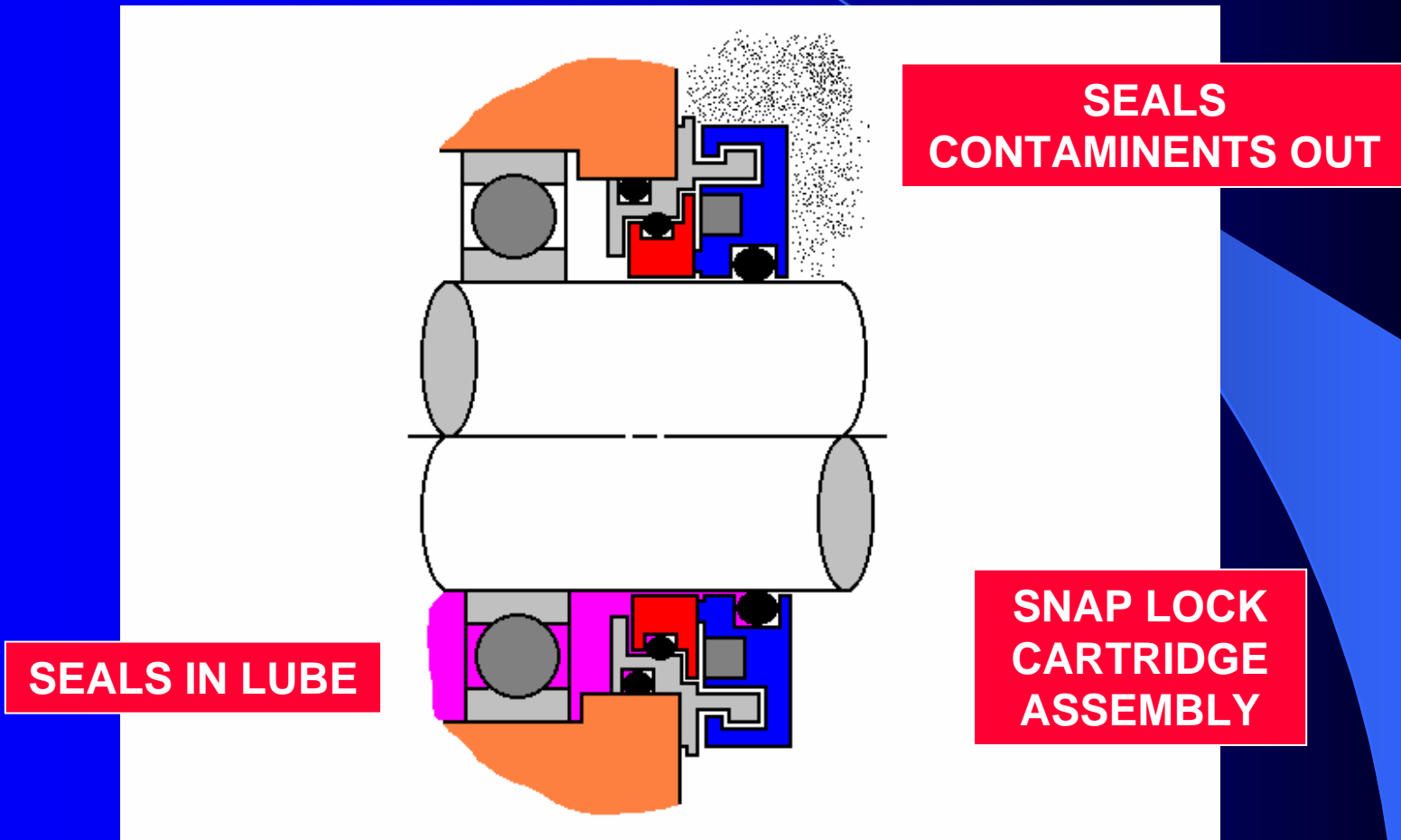

# MAGNUM-C

- One piece cartridge installation
- Corrosion resistant composite rotor
- Interlocking labyrinth protects faces
- Controlled range magnetic face loading
- Handles axial shaft movement
- Wide range of sizes 3/4" to 8"



# MAGNUM-S



**ISOMAG**



# MAGNUM-S

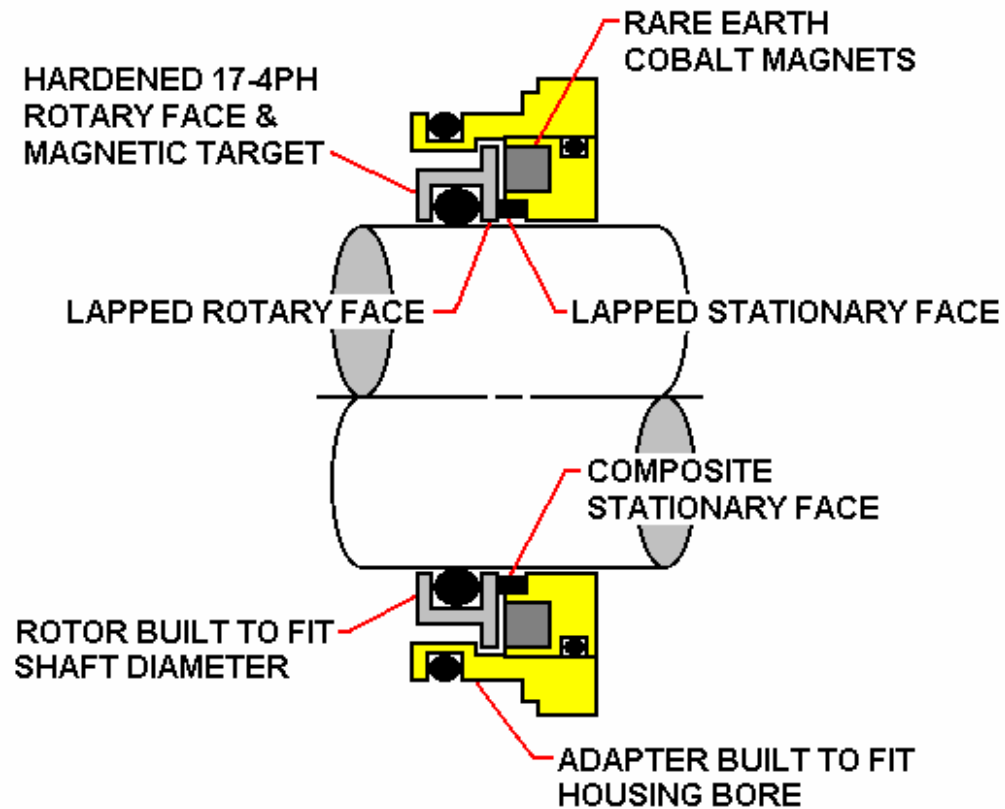

# MAGNUM-S

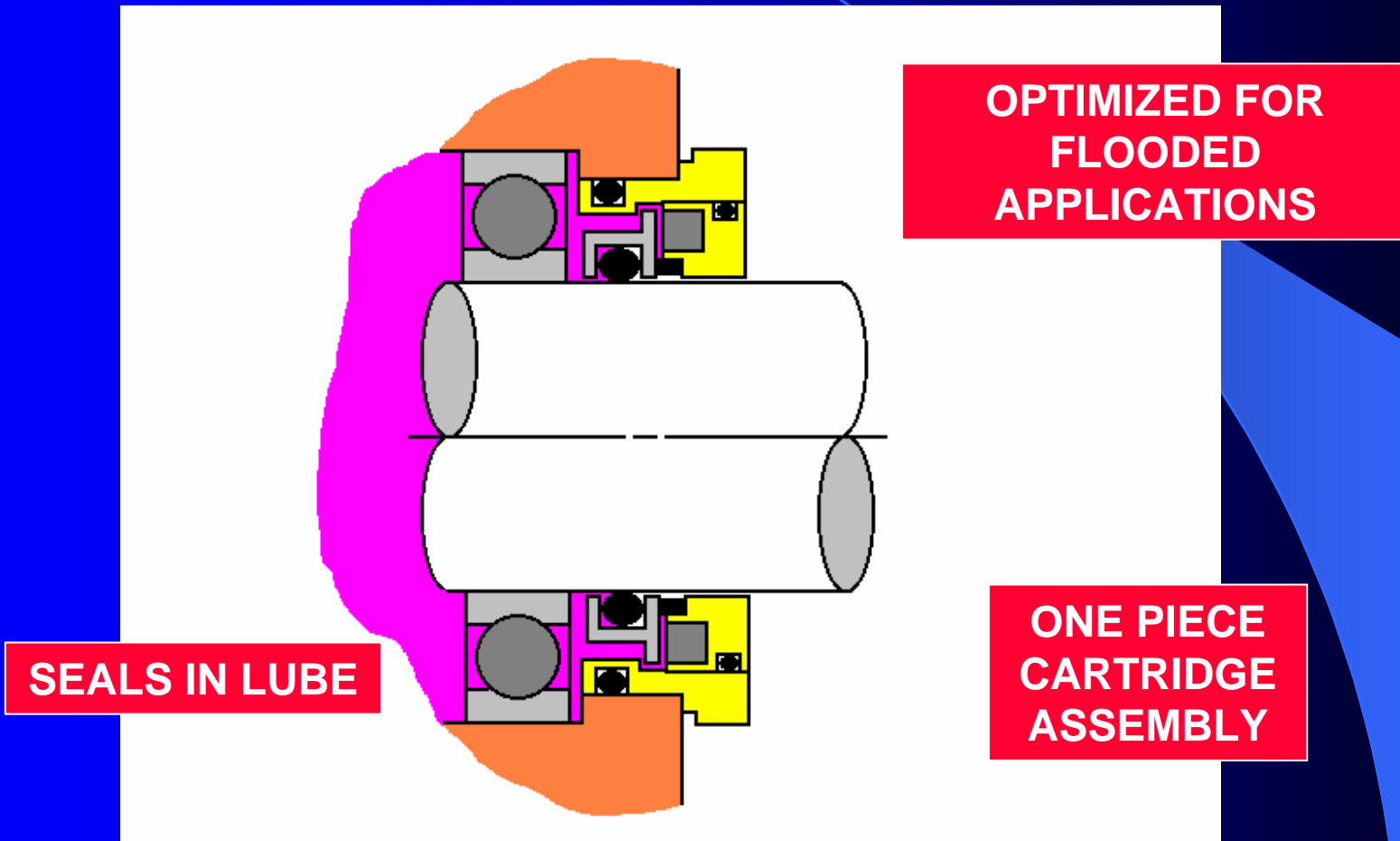

# **MAGNUM-S**

## **Cartridge Bearing Seal**

- **Optimized for flooded applications**
- **One piece cartridge installation**
- **Low mass high speed rotor**
- **Controlled range magnetic face loading**
- **Handles axial shaft movement**
- **Wide range of sizes 3/4" to 13"**



# Custom Designs

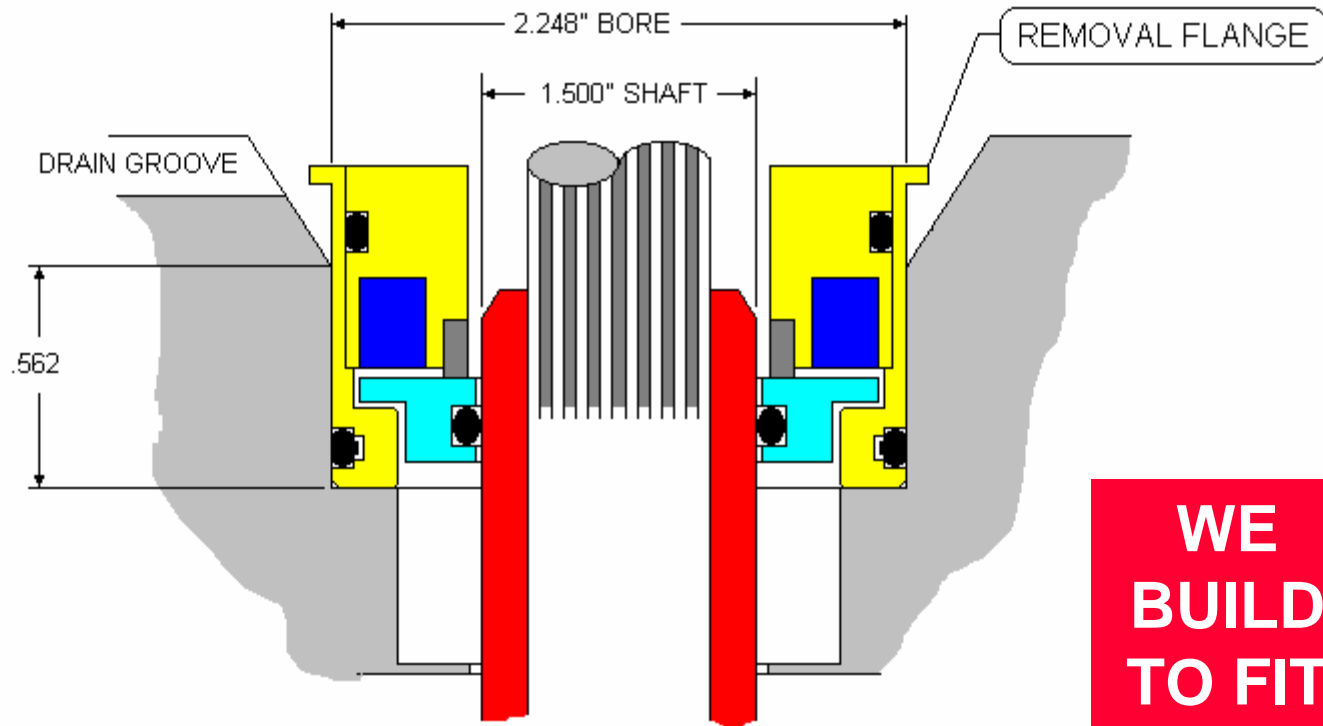

ISOMAG MAGNUM-S BEARING SEAL  
INSTALLED IN UPPER GEAR BOX  
OF SUNDYNE PUMP 1.500" SHAFT DIA.



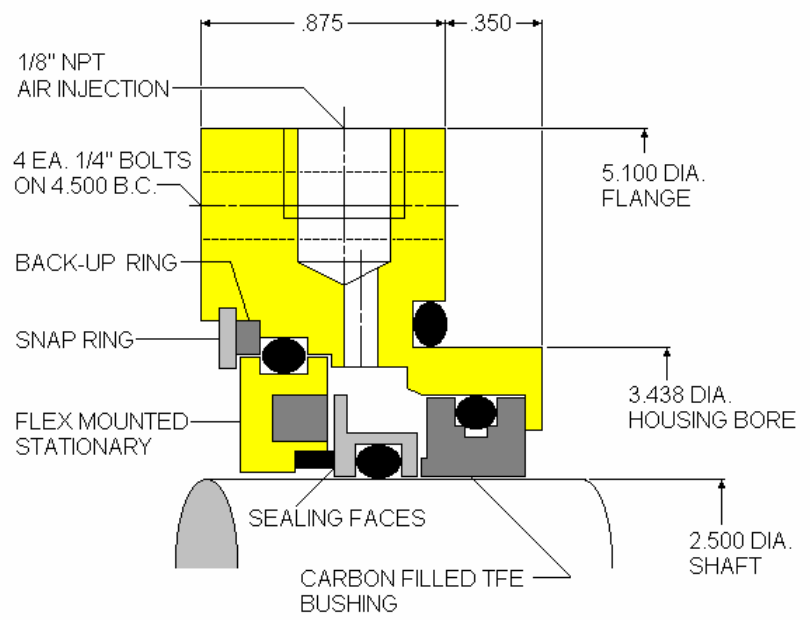

ALL DIM. PROVIDED BY CUSTOMER  
 DESIGNED TO FIT  
 FULLER ROTARY FEEDER

PROPOSAL DRAWING

	<i>DURABLE          BY          DESIGN</i>
	TYPE MAGNUM - F SEAL ASSY CODE 2500MFX BF5100 P.I.N. NOT ASSIGNED

